



CONTRABAND DETECTOR PM2030

Contraband Detector PM2030 of nondestructive examination is a portable security instrument that detects hidden items (drugs, explosives, weapons, currency, etc.) within the closed cavities of transport vehicles, freight containers and other objects.

PM2030 can be applied in field condition, where stationary examination equipment can not be used. The Contraband Detector indicates the presence of sealed radioactive material in any closed volumes (freight containers, automobile tires, doors, bumpers, fuel tanks, train carriages, etc.).

Functions

- Search for illegal objects
- Density indication of illegal object
- Formation of scanned objects library
- Search for gamma-radiation sources
- Data transfer to PC via USB

Application

- Customs and Border Patrol
- Police
- Security Offices

Features

Surely detects hidden items by depth of scanning to 150 mm

The device modular design for the scan unit application in hard-to-reach places

Telescopic extension pole for large objects examination

Vibration alarm from the handle for invisible detection and for work in noisy places

Wireless sound alarm by Bluetooth 4.0

Complies with the requirements of IAEA "Technical and Functional Specification for Border Monitoring Equipment" in gamma-radiation sources search mode

CONTRABAND DETECTOR PM2030

Design

The Contraband Detector features the plastic case and consists of two units: display and control unit and scan unit with rubber handle.



Operation Principle

In the operation mode the detector emits a beam of gamma radiation into the object being inspected and measures the backscatter. PM2030 features the built-in radiation source ¹³³Ba with activity 350-380 kBq (10 µCi). The source is housed within the lead safety container-collimator of the scan unit.

The intensity of the backscatter depends on the illegal object features (its density and size). The device is moved along the surface of the object.

The change of the backscatter's intensity is displayed on LCD and accompanied with light, sound and vibration alarms. The frequency of alarm repetition depends on the size and density of the detected cavity or items.

The lead container-collimator provides the necessary narrow zone of the object radiation during examination and complete protection of the operator from gamma radiation.

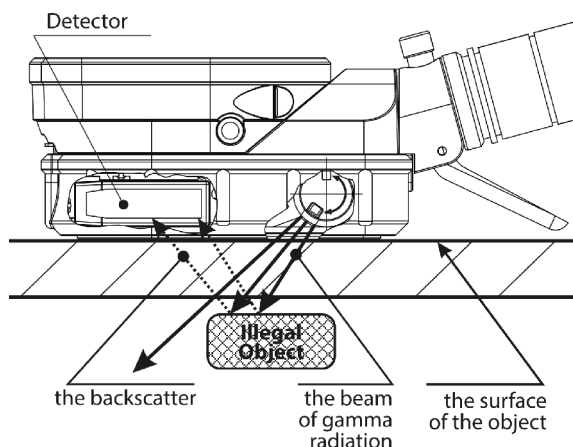

Specifications

When scanning **behind 1 mm steel partition or 15 mm wood partition**, with the speed no more than **5 cm/s**, PM2030 detects hidden **bars**:

- aluminium 30x30x30 mm
- polyethylene 70x70x20 mm
- steel 30x30x10 mm

Alarms

- Audio
- Visual
- Vibration

Power supply

- From two AA (LR6) standard batteries of voltage 1.5 B (-0.3; +0.1) V or
- From two rechargeable batteries of voltage 1.3 B (-0.1; +0.1) V
- From the USB of PC
- external 90-260V AC 50/60Hz / 5V
- From car's lighter socket via USB adapter 12V/5V

Battery lifetime (up to low battery warning indication)) no less than 50 hours

Environmental protection	IP65
Weight , no more	1.2 kg
Dimensions , no more	290x90x100 mm

Reliability

- mean time between failures, at least 20,000 hours
- mean service lifetime, for at least 8 years
- mean recovery time, no more than 60 min

Operation Conditions

- Ambient air temperature -30 up to +50°C
- Relative humidity (at 40 °C and at a lower) up to 98%
- Atmospheric pressure from 84 up to 106.7 kPa

Optional Accessories

for large objects examination:

- Telescopic extension pole 1.5 m
- Telescopic extension pole 3 m
- Case
- Wireless head phones (Bluetooth 4.0)



Design and specifications of the system can be changed without further notice.

America

Polimaster Inc.
44873 Falcon Place, Suite 128
Sterling, VA 20166, USA
Phone: +1 703 525 5075
Fax: +1 703 525 5079
info@polimaster.us

www.polimaster.us

Europe

Polimaster Europe UAB
Ezero Str. 4, LT-13264 Didziasalis,
Vilnius region, Republic of Lithuania
Phone: +370 5 210 2323
Fax: +370 5 210 2322
polimaster@polimaster.lt

www.polimaster.eu

Asia, Africa, Australia and Oceania

Polimaster Ltd.
51, Skoriny St., Minsk
220141, Republic of Belarus
Phone: +375 17 396 3675
+375 17 268 6819
Fax: +375 17 264 2356
polimaster@polimaster.com
www.polimaster.com

Japan

Polimaster Japan K.K.
AUBE2 5-177 Kuratsuki
Kanazawa, Ishikawa Prefecture
920-8203 Japan
Phone: + 81 076 201 8623
Fax: + 81 076 201 8624
pacific@polimaster.jp
www.polimaster.jp